

Solar-Powered LED Buoy Lights

High-Intensity LED Navigation Lights

LRM T-82 Two-Mile Light



THE T82 FLEXPOWER ADVANTAGE

- Enhanced marine safety at minimal cost
- Easy installation - just bolt lantern down
- Stainless Steel / Polycarbonate construction
- Works in any location even fully shaded areas
- Fits on small or large buoys
- Proven reliability and performance

The T82 Solar/Primary LED Marine Lantern: All components including LEDs, advanced time variable pulse modulated controller, flexpower converter and user replaceable batteries are protected inside the durable polycarbonate enclosure.

The T82 is the only available Marine Lantern to offer high performance and reliability in a compact, serviceable, no/low maintenance package combined with LRM's proprietary flexpower technology. It is ideal for marker buoys, docks, marinas, mines, aquaculture sites, or any other on or offshore application. The T82 provides two nautical miles of visibility and will be the last marine light you will ever need. Unlike many two-mile lights on the market today, the T82 has been engineered to last an estimated 10 to 15 years.

With its sturdy polycarbonate/stainless steel construction, the T82's advanced microprocessor controlled electronics and user replaceable batteries provide the ultimate in reliability and convenience. Rugged construction with an integral precision machined o-ring seal provides a water tight enclosure with superior shock and vibration resistance. The T82, with it's quick release lens clamps make on site battery replacement a simple task using just a screwdriver.

The flexpower advantage. The T82 is the only commercially available marine lantern design to be powered by NiMhd, NiCd, and Alkaline or Sealed Lead Acid batteries. The T82 will nUI up to 1 year* on a single pair of alkaline D cells and is perfect for locations where solar charging is not possible. The T82 is available in amber, red, green, white, or blue and can be shipped from stock for quick delivery in any of the 8 most commonly used flash patterns.

Contact us for more information

760.754.2400 Fax .2485

info@oceanscience.com

www.oceanscience.com

4129 Avenida de la Plata

Oceanside, CA 92056



LRM T-82 SPECIFICATIONS

Colors: Amber, Red, Green, White, and Blue

Flash Patterns: 10, 15, 20, 30, 60 FPM, VQ(3)5S, VQ.5S, Steady

Vertical Divergence: 7 degrees

Expected Service Life: 25 years (Battery replacement every 5 years)

Light source: 5 high intensity LEDs

Materials: Polycarbonate lens and base, Stainless Steel clamps

Temperature Range: -25 to +70 degrees Celsius

Weight: 800 grams

Warranty: 3 years

LRM T-82 OPERATING CHARACTERISTICS

Color	Duty Cycle	Intensity (Candelas)	Visibility (na. Miles)	Autonomy* (hours)	Average** recharge
Amber	12.5%	5.0	2.0	>350	<2.0
Amber	100%	1.5	1.2	>350	<2.0
Red	12.5%	5.0	2.0	>350	<2.0
Red	100%	1.5	1.2	>350	<2.0
Green	12.5%	5.0	2.0	>350	<2.0
Green	100%	1.5	1.2	>350	<2.0
White	12.5%	5.0	2.0	>350	<2.0
White	100%	1.5	1.2	>350	<2.0

*continuous hours of operation from full charge to battery depletion

**recharge time required to maintain full charge based on 14 hours of operation per night

T82 SOLAR/PRIMARY LED

Marine Lantern

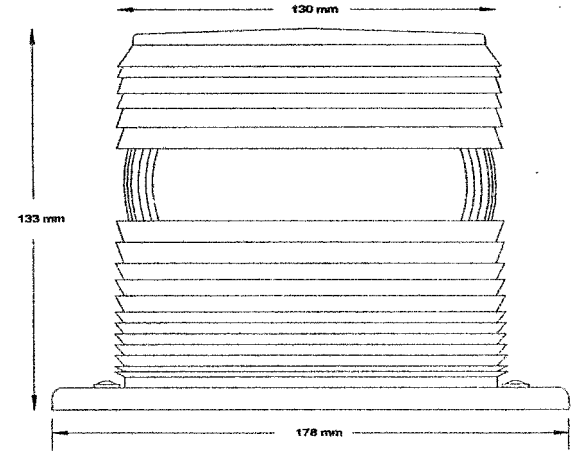

Height: 133 mm
Mounting Flange Width: 178 mm
Lens Diameter: 130 mm

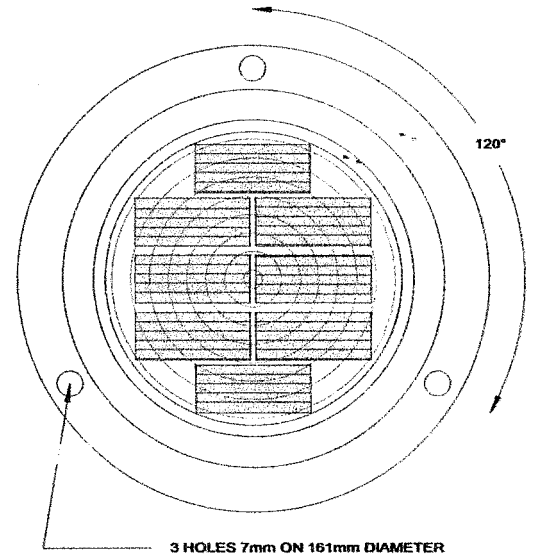

Contact us for more information

760.754.2400 Fax .2485

info@oceanscience.com

www.oceanscience.com

4129 Avenida de la Plata

Oceanside, CA 92056

